



**BERYLLIUM-CONTAINING MATERIALS
FOUNDRY MELTING & CASTING
EXPOSURE CONTROL GUIDE**



Rue de l'Industrie 4, B-1000 Brussels
Tel: +32 (0)2 213 74 20
Email: info@beryllium.eu
www.berylliumsafety.eu

BERYLLIUM (BE) – CONTAINING ALLOYS

Beryllium-containing alloys, in solid form and as contained in finished products present no special health risks.



However, some manufacturing operations are known to generate airborne particulate and like many industrial materials, melting and casting operations of beryllium-containing alloys present a health risk if effective controls are not implemented.

The inhalation of beryllium-containing dust, mist or fume can cause a serious lung condition in some individuals. The degree of hazard varies depending on the form of the product and how the material is processed and handled. You must read the product specific Safety Data Sheet (SDS) for additional environmental, health and safety information before working with any beryllium-containing alloys.

The use of engineering and work practice controls are the preferred methods of controlling exposure to beryllium-containing particulate reliably below the BeST Recommended Exposure Guideline (REG) of 0.6 microgram of beryllium per cubic meter of air ($\mu\text{g}/\text{m}^3$) (Inhalable), measured as an 8-hour time weighted average (TWA) or the occupational exposure limit (OEL) applicable to the Member State for airborne beryllium.

Local Exhaust Ventilation

All visible releases of melting and casting fume are of concern and need to be controlled to prevent release into the work environment. Process ventilation is required where beryllium-containing particulate is generated in a manner where there is potential for worker exposure. Local exhaust ventilation (LEV) is the preferred control technology. Where utilized, exhaust inlets/hoods are generally positioned as close as possible to the source of generated airborne particulate.



Another method of control is to conduct the operations in a ventilated enclosure designed to contain all particulate within the enclosure and away from the operator's breathing zone.

Critical ventilation parameters, such as velocity, particle capture area, distance from the source and air flow rate, are influenced by the nature of the process being controlled. There is no single set of design parameters that will be effective for all operations. The operations and the process variations requiring ventilation are too numerous to list

here. However, the American Conference of Governmental Industrial Hygienists (ACGIH) publishes a guide to effective ventilation system design entitled, "Industrial Ventilation: A Manual of Recommended Practice". The ACGIH publication describes ventilation systems for a wide range of operations. These ventilation designs, properly implemented with sensible shop practice, can provide worker protection from beryllium exposures. Use qualified professionals to design and install ventilation systems.

As part of the ventilation equipment, process exhaust air should be directed through a High Efficiency Particulate Air (HEPA) filtering device to the outdoors where it will not be recirculated back to the work area.

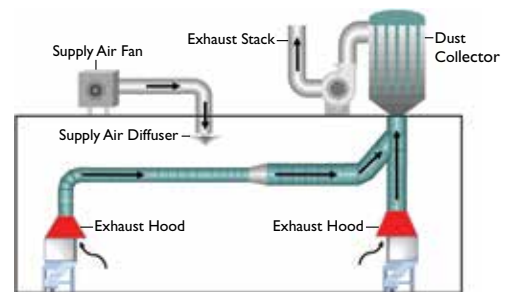
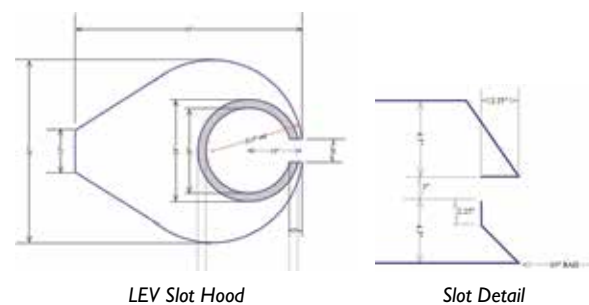

Ventilation equipment must be inspected regularly to ensure it is functioning properly. Provide training on the use, operation and maintenance of ventilation systems to all users.

DROSS HANDLING

Careful attention to engineering and work practice controls must be given to dross handling operations. A successful engineering control design is to closely integrate the dross handling LEV hood with the furnace LEV hood.

FURNACE TOOLS

When removed from molten metal, furnace tools such as rub bars, skim bars, and thermocouple tips will release fume. These tools should be placed in a LEV hood after each use.

PERSONAL PROTECTIVE EQUIPMENT (PPE)

When engineering and/or work practice controls are not practical or effective, personal protective equipment (PPE) must be used to prevent skin contact and inhalation of beryllium-containing particulate. Instruct operators to wear gloves when handling parts that are not visibly clean.



Ensure that work clothing, e.g. pants and shirts, are maintained in a visibly clean condition when there is potential for contact with beryllium-containing particulate or solutions.

When airborne exposures exceed or have the potential to exceed REG or OEL, approved respirators must be used as specified by an industrial hygienist or other qualified professional

MAINTENANCE

Under certain conditions the repair or maintenance of equipment can generate airborne particles. Protecting workers can require the use of specific work practices or procedures involving the combined use of ventilation, wet and vacuum cleaning methods, respiratory protection, decontamination, special protective clothing and when necessary, restricted work zones. Detailed procedures for safely maintaining the process equipment and ventilation systems should be developed. All operators and maintenance personnel need to be trained in the established procedures prior to performing maintenance or service activities. The procedures should detail the use of wet methods or HEPA vacuuming, ventilation and appropriate PPE to prevent exposures to airborne particles.



HOUSEKEEPING

Good work practices and the implementation of procedures for keeping melting and casting work areas and floors clean and free of beryllium-containing alloy chip accumulations are important methods for maintaining exposures reliably below the REG or applicable OEL. The use of compressed air or brooms for cleaning should be prohibited. Wet cleaning and HEPA vacuuming are effective methods for cleaning. Disposable rags, towels or wipes should be used to wet clean, not be allowed to dry out and must be kept in a closed container. Rags and towels should not be reused.



WORKPLACE EXPOSURE CHARACTERIZATION

In accordance with good industrial hygiene practice, a characterization of worker exposure, including air monitoring, should be conducted for operations where a potential for beryllium exposure exists.

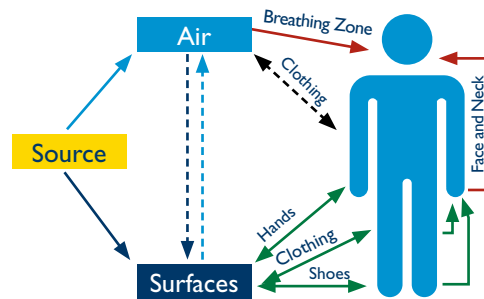

RECYCLING / DISPOSAL

Beryllium-containing scrap is a valuable material and should be recycled whenever possible. Beryllium-containing scrap should be kept segregated from other metals to retain its higher value as a recyclable material.



If not recyclable, materials containing beryllium are considered waste and must be disposed in accordance with applicable EU and Member State regulations. Beryllium-containing wastes should be maintained in a moist condition during collection, storage and disposal, double bagged in plastic and sealed in an appropriate container to minimize the potential for release and exposure.

ADDITIONAL INFORMATION

Additional worker protection guidance can be obtained online at www.berylliumssafety.eu or by contacting the **Beryllium Industry Science & Technology Association (BeST)** at: Rue de l'Industrie 4, B-1000 Brussels, **Tel:** +32 (0)2 213 74 20 | **Email:** info@beryllium.eu

This document has been prepared using information and data from sources considered to be technically reliable and is believed to be correct. BeST makes no warranties, expressed or implied, as to the accuracy of the information contained herein. BeST cannot anticipate all conditions under which this information and the subject products may be used and the actual conditions of use are beyond its control. The user is responsible to evaluate all available information when using the subject product for any particular use and to comply with all federal, state, provincial and local laws, directives, statutes and regulations.